

Drawind #: 60226-P
Custom 60226-P

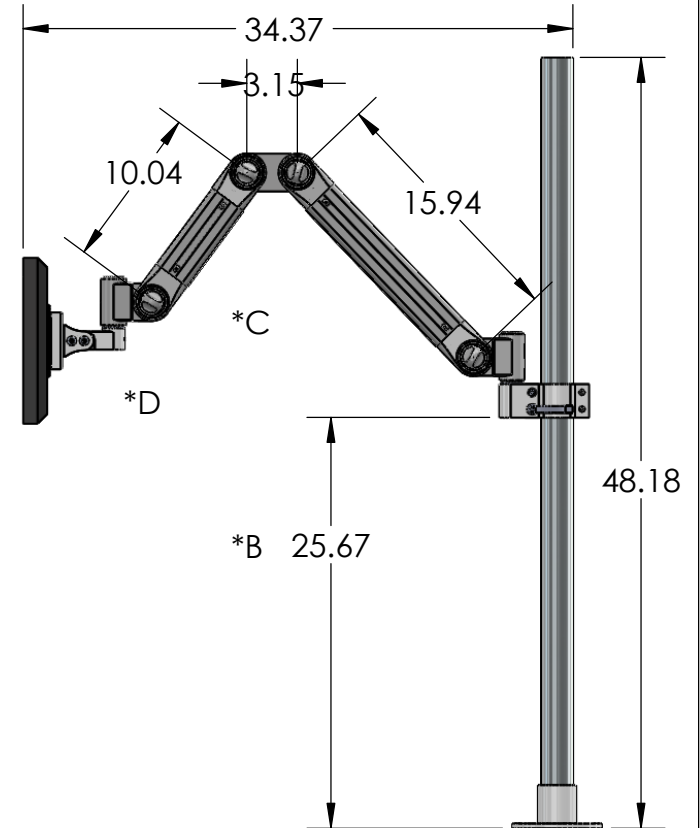
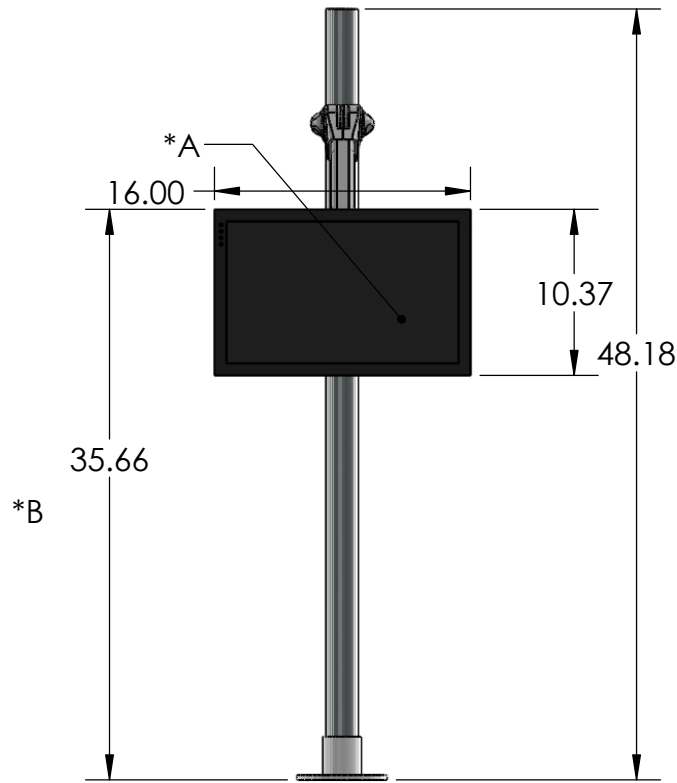
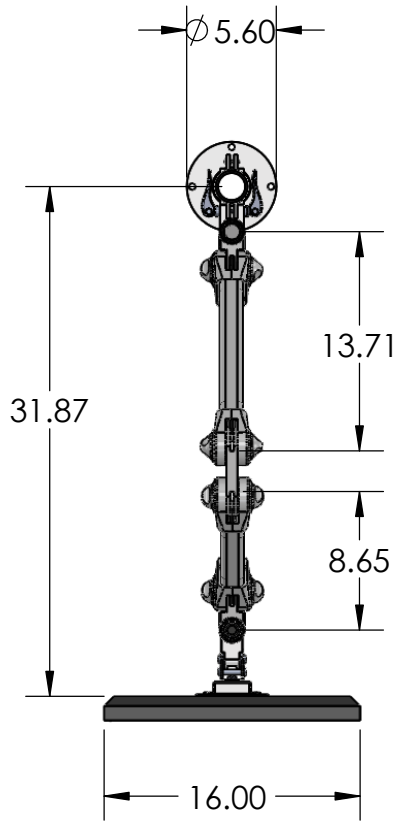

- *A: Monitor shown is for visal purposes only. Custom monitor dimensions may vary from monitor shown.
- *B: 25-40 Pole bracket is height adjustable. Dimensions shown may vary based on desired height.
- *C: Dual Adjustable arm can be positioned in multiple positions. Dimensions shown may vary based on desired palcement.
- *D: Mounting the 21-01 pivot bracket on the bottom side of the monitor arm allows the monitor to be adjusted to customers desired position.

PROPRIETARY AND CONFIDENTIAL
THE INFORMATION CONTAINED IN THIS DRAWING IS THE SOLE PROPERTY OF CUSTOM PRODUCTS AND SERVICES. ANY REPRODUCTION IN PART OR AS A WHOLE WITHOUT THE WRITTEN PERMISSION OF CUSTOM PRODUCTS AND SERVICES IS PROHIBITED.

		UNLESS OTHERWISE SPECIFIED:		NAME	DATE		
		DIMENSIONS ARE IN INCHES		DRAWN	NJN	12/18/15	TITLE: Custom 60226-P Dual Adjustable LCD Monitor Display
		TOLERANCES:		CHECKED			
		FRACTIONAL ±		ENG APPR.			
		ANGULAR: MACH ± BEND ±		MFG APPR.			
		TWO PLACE DECIMAL ±		Q.A.			SIZE DWG. NO. REV A 60226-P
		THREE PLACE DECIMAL ±		COMMENTS:			
		INTERPRET GEOMETRIC TOLERANCING PER:					SCALE: 1:24 WEIGHT: SHEET 1 OF 1
		MATERIAL					
NEXT ASSY	USED ON	FINISH					
APPLICATION		DO NOT SCALE DRAWING					

Drawing #: 60226-P
60226 Individual Part Drawing

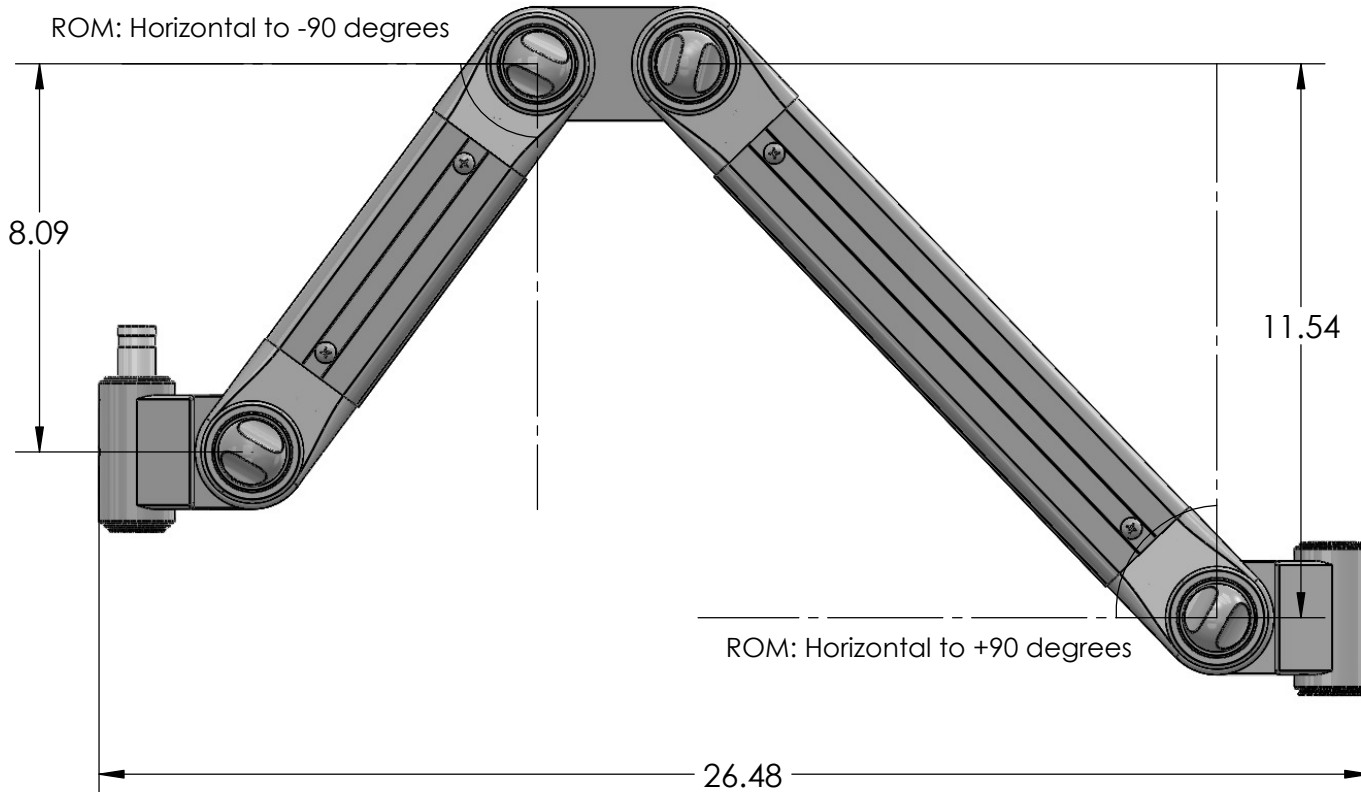
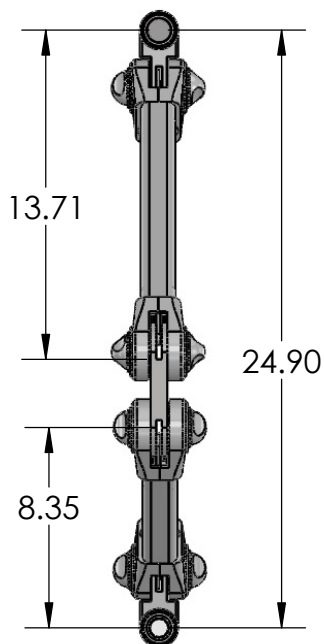
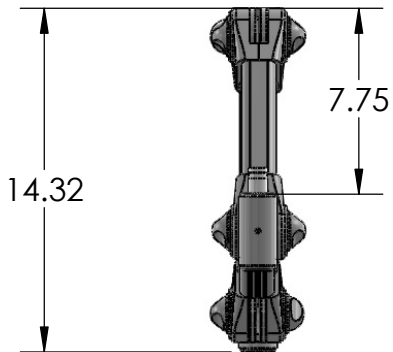

PROPRIETARY AND CONFIDENTIAL
THE INFORMATION CONTAINED IN THIS DRAWING IS THE SOLE PROPERTY OF CUSTOM PRODUCTS AND SERVICES. ANY REPRODUCTION IN PART OR AS A WHOLE WITHOUT THE WRITTEN PERMISSION OF CUSTOM PRODUCTS AND SERVICES IS PROHIBITED.

		UNLESS OTHERWISE SPECIFIED:		NAME	DATE	
		DIMENSIONS ARE IN INCHES	DRAWN	NJN	10/28/14	
		TOLERANCES:	CHECKED			TITLE:
		FRACTIONAL ±	ENG APPR.			
		ANGULAR: MACH ± BEND ±	MFG APPR.			
		TWO PLACE DECIMAL ±	Q.A.			
		THREE PLACE DECIMAL ±	COMMENTS:			
		INTERPRET GEOMETRIC TOLERANCING PER:				SIZE DWG. NO. REV
		MATERIAL				A 60226-P
NEXT ASSY	USED ON	FINISH				
APPLICATION		DO NOT SCALE DRAWING				SCALE: 1:12 WEIGHT: SHEET 1 OF 1

5

4

3

2

1